



ELECTROSTEEL USA

VALUE. QUALITY. COMPLIANCE | PRODUCT SPECIFICATIONS



NSF / ANSI/CAN61
<MH61191>



ISO14001
CERTIFIED

25
EDITION

3" - 24" DUCTILE IRON MECHANICAL JOINT COMPACT FITTINGS

GENERAL SPECIFICATIONS

- Material:** ASTM A536 specified ductile iron
- Pressure:** 3" - 24" diameter rated at 350PSI
- Testing:** Strictly adheres to ANSI/AWWA C153/A21.53 and UL requirements
- Laying Length:** Maintains ANSI/AWWA C153/A21.53 requirements
- Weights:** In pounds, unless otherwise noted, does not include accessories, coatings or linings
- Flanges:** All flanges adhere to ANSI/ASSA C115/A21.15 and ANSI B16.1 class 125 flanges
- Cement Lining:** Conforms to ANSI/AWWA C104/A21.4 – size 3" - 24" single thickness
- Coating:** Asphaltic coating inside and out conforms to ANSI/AWWA C104/A21.4
- Gaskets:** Produced to ANSI/AWWA C111/A21.11 standards
- T-Bolts/Nuts:** Low alloy steel conforming to ANSI/AWWA C111/A21.11 requirements
- Approvals:** 3"-12" FM : 3"-24" UL : 3"-12" UL/NSF-61
- Dimensions:** Unless otherwise noted, all dimensions in inches

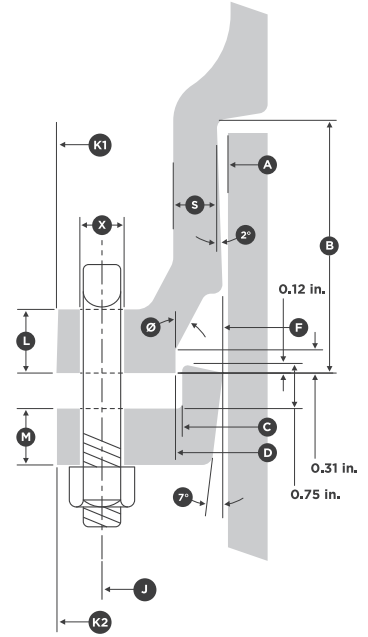

Mechanical Joint Dimensions

NOM SIZE	A DIA.	B	C DIA.	D DIA.	F DIA.	J DIA.	K1 DIA.	K2. DIA.	L	M	S	Ø	X DIA.	BOLTS	
														SIZE	NO.
3	3.96	2.50	4.84	4.94	4.06	6.91	7.62	7.69	0.58	0.62	0.39	28°	3/4	5/8 x 3	4
4	4.80	2.50	5.92	6.02	4.90	7.50	9.06	9.12	0.60	0.75	0.39	28°	7/8	3/4 x 31/2	4
6	6.90	2.50	8.02	8.12	7.00	9.50	11.06	11.12	0.63	0.88	0.43	28°	7/8	3/4 x 31/2	6
8	9.05	2.50	10.17	10.27	9.15	11.75	13.31	13.37	0.66	1.00	0.45	28°	7/8	3/4 x 3 1/2	6
10	11.10	2.50	12.22	12.34	11.20	14.00	15.62	15.62	0.70	1.00	0.47	28°	7/8	3/4 x 3 1/2	8
12	13.20	2.50	14.32	14.44	13.30	16.25	17.88	17.88	0.73	1.00	0.49	28°	7/8	3/4 x 3 1/2	8
14	15.30	3.50	16.40	16.54	15.44	18.75	20.25	20.25	0.79	1.25	0.55	28°	7/8	3/4 x 4	10
16	17.40	3.50	18.50	18.64	17.54	21.00	22.50	22.50	0.85	1.31	0.58	28°	7/8	3/4 x 4	12
18	19.50	3.50	20.60	20.74	19.64	23.25	24.83	24.75	1.00	1.38	0.68	28°	7/8	3/4 x 4	12
20	21.60	3.50	22.70	22.84	21.74	25.50	27.08	27.00	1.02	1.44	0.69	28°	7/8	3/4 x 4	14
24	25.80	3.50	26.90	27.04	25.94	30.00	31.58	31.50	1.02	1.56	0.75	28°	7/8	3/4 x 4 1/2	16

3" - 24" FITTING CONFIGURATIONS

Fittings are available in most standard Mechanical Joint and Flanged configurations.

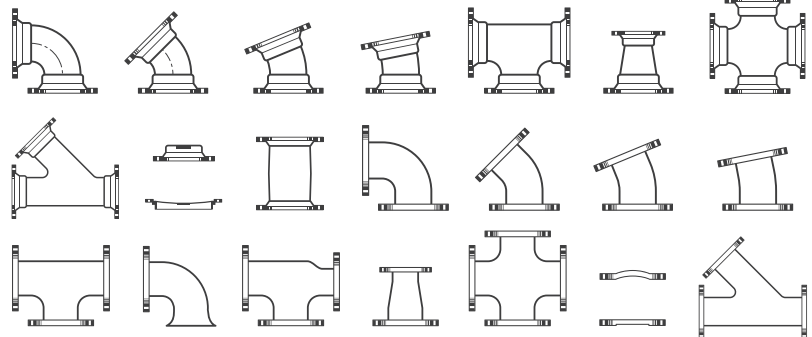

NOMINAL SIZE	A DIAMETER MIN	A DIAMETER MAX	B BELL OUTER DIAMETER	C SOCKET DEPTH
3	3.90	4.02	5.80	3.00
4	4.74	4.86	6.86	3.15
6	6.84	6.96	8.75	3.38
8	8.99	9.11	11.05	3.69
10	11.04	11.16	13.15	3.75
12	13.14	13.26	15.30	3.75
14	15.22	15.35	17.85	5.00
16	17.32	17.45	20.00	5.00
18	19.42	19.55	22.10	5.00
20	21.52	21.65	24.25	5.50
24	25.72	25.85	28.50	5.95
30	31.94	32.08	35.40	6.55
36	38.24	38.38	41.84	7.00



ANSI/AWWA C151/A21.51 guidelines for push-on joints used in creating table. Subject to manufacturing tolerances. Dimensions in inches.

PRESSURE CLASS | Thickness, Dimensions & Weight

SIZE	PRESSURE CLASS psi [†]	THICKNESS	CASTING TOLERANCES	18 FT LAYING LENGTH	
				WEIGHT PER LENGTH (LBS)*	AVG WEIGHT PER FOOT (LBS)**
3	350	0.25 ^{††}	0.05	165	9.3
4	350	0.25 ^{††}	0.05	205	11.4
6	350	0.25 ^{††}	0.05	300	16.6
8	350	0.25 ^{††}	0.05	395	22.0
10	350	0.26	0.06	510	28.4
12	350	0.28	0.06	655	36.4
14	250	0.28	0.07	770	42.9
14	300	0.30	0.07	825	45.8
14	350	0.31	0.07	850	47.2
16	250	0.30	0.07	940	52.3
16	300	0.32	0.07	1000	55.5
16	350	0.34	0.07	1060	58.8
18	250	0.31	0.07	1090	60.5
18	300	0.34	0.07	1185	65.9
18	350	0.36	0.07	1250	69.5
20	250	0.33	0.07	1290	71.6
20	300	0.36	0.07	1395	77.6
20	350	0.38	0.07	1470	81.6
24	200	0.33	0.07	1550	86.1
24	250	0.37	0.07	1725	95.8
24	300	0.40	0.07	1855	103.0
24	350	0.43	0.07	1985	110.2
30	150	0.34	.07	2000	111.20
30	200	0.38	.07	2220	123.20
30	250	0.42	.07	2435	135.20
30	300	0.45	.07	2595	144.20
30	350	0.49	.07	2810	156.10
36	150	0.38	.07	2675	148.70
36	200	0.40	.07	2935	163.10
36	250	0.47	.07	3260	181.10
36	300	0.51	.07	3520	195.50
36	350	0.56	.07	3840	213.40

- Thicknesses and dimensions of 3" – 36" ductile iron pipe adhere to ANSI/AWWA C151/A21.51. Weights may vary due to slight variations in bell weights. Thickness and diameter in inches.
- Weight of pipes shall be as per the standard.
- * Calculated weight, including bell, of pipe rounded off to nearest 5 lbs.
- ** Average weight, per foot, based on calculated weight of pipe before rounding, including bell.
- Table above based on ANSI/AWWA C150/A21.50 and includes 0.08" service allowance and casting tolerance by size. Dimensions in inches.
- † Pressure Classes determined by water pressure of the pipe measured in psi. Thicknesses rated to water pressure with additional 100 psi surge pressure. Calculations reflect minimum yield strength of 42,000 psi and 2.0 safety factor times the sum of the working pressure and 100 psi surge allowance.
- †† Calculated thickness less than shown above. These are the lowest nominal thicknesses available in these sizes.

SIZE	MAXIMUM JOINT DEFLECTION (DEG)	DEFLECTION (IN)	RADIUS PRODUCED BY SUCCESSION OF JOINTS (FT)
3 - 30	5°	19	205
36	1.5°	6 (5.7)	692

THICKNESS CLASS | Thickness, Dimensions & Weight

SIZE	THICKNESS CLASS	THICKNESS	18 FT LAYING LENGTH	
			WEIGHT PER LENGTH (LBS)*	AVG WEIGHT PER FOOT (LBS)**
3	51	0.25	165	9.3
3	52	0.28	185	10.3
3	53	0.31	205	11.3
3	54	0.34	220	12.2
3	55	0.37	235	13.2
3	56	0.40	255	14.1
4	51	0.26	210	11.8
4	52	0.29	235	13.1
4	53	0.32	255	14.3
4	54	0.35	280	15.5
4	55	0.38	300	16.6
4	56	0.41	320	17.8
6	50	0.25	300	16.6
6	51	0.28	330	18.4
6	52	0.31	365	20.2
6	53	0.34	395	22.0
6	54	0.37	430	23.8
8	50	0.27	425	23.7
8	51	0.30	470	26.1
8	52	0.33	515	28.6
8	53	0.36	560	31.0
8	54	0.39	600	33.4
8	55	0.42	645	35.7
8	56	0.45	685	38.1
10	50	0.29	565	31.4
10	51	0.32	620	34.5
10	52	0.35	675	37.5
10	53	0.38	730	40.5
10	54	0.41	780	43.4
12	50	0.31	720	40.0
12	51	0.34	785	43.6
12	52	0.37	850	47.2
12	53	0.40	915	50.8
12	54	0.43	980	54.4
12	55	0.46	1040	57.9
12	56	0.49	1105	61.5

SIZE	THICKNESS CLASS	THICKNESS	18 FT LAYING LENGTH	
			WEIGHT PER LENGTH (LBS)*	AVG WEIGHT PER FOOT (LBS)**
14	50	0.33	900	50.0
14	52	0.39	1050	58.4
14	53	0.42	1125	62.6
14	54	0.45	1200	66.7
16	50	0.34	1060	58.8
16	51	0.37	1145	63.6
16	52	0.40	1230	68.4
16	53	0.43	1315	73.1
16	54	0.46	1400	77.9
16	55	0.49	1490	82.7
16	56	0.52	1575	87.4
18	50	0.35	1220	67.7
18	51	0.38	1315	73.1
18	52	0.41	1415	78.4
18	53	0.44	1510	83.9
18	54	0.47	1605	89.3
20	50	0.36	1395	77.6
20	51	0.39	1505	83.6
20	52	0.42	1615	89.6
20	53	0.45	1720	95.6
20	54	0.48	1830	101.6
24	50	0.38	1765	98.1
24	51	0.41	1895	105.4
24	52	0.44	2025	112.6
24	53	0.47	2155	119.7
24	54	0.50	2285	126.9
24	55	0.53	2415	134.1
24	56	0.56	2540	141.2
30	50	0.39	2270	126.2
30	51	0.43	2490	138.2
30	52	0.47	2705	150.2
30	53	0.51	2920	162.1
36	50	0.43	3000	166.7
36	51	0.48	3325	184.7
36	52	0.53	3645	202.6
36	53	0.58	3970	220.5

- Thicknesses and dimensions of 3" - 36" ductile iron pipe adhere to ANSI/AWWA C151/A21.51. Weights may vary due to slight variations in bell weights. Thickness and diameter in inches.
- Weight of pipes shall be as per the standard.
- * Calculated weight, including bell, of pipe rounded off to nearest 5 lbs.
- ** Average weight, per foot, based on calculated weight of pipe before rounding, including bell.

RATED WORKING PRESSURE AND MAXIMUM DEPTH OF COVER*

NOMINAL SIZE	PRESSURE ¹ CLASS PSI	NOMINAL THICKNESS	LAYING CONDITIONS				
			TRENCH TYPE 1	TRENCH TYPE 2	TRENCH TYPE 3	TRENCH TYPE 4	TRENCH TYPE 5
			MAX DEPTH OF COVER ² (FT)				
3	350	0.25	78	88	99	100‡	100‡
4	350	0.25	53	61	69	85	100‡
6	350	0.25	26	31	37	47	65
8	350	0.25	13	20	25	34	50
10	350	0.26	11	15	19	28	45
12	350	0.28	10	15	19	28	44
14	250	0.28	**	11	15	23	36
14	300	0.30	**	13	17	26	42
14	350	0.31	**	14	19	27	44
16	250	0.30	**	11	15	24	34
16	300	0.32	**	13	17	26	39
16	350	0.34	**	15	20	28	44
18	250	14	**	10	14	22	31
18	300	17	**	13	17	26	36
18	350	19	**	15	19	28	41
20	250	0.33	**	10	14	22	30
20	300	0.36	**	13	17	26	35
20	350	0.38	**	15	19	28	41
24	200	0.33	**	8	12	17	25
24	250	0.37	**	11	15	20	29
24	300	0.40	**	13	17	24	32
24	350	0.43	**	15	19	28	37
30	150	0.34	††	--	9	14	22
30	200	0.38	††	8**	12	16	24
30	250	0.42	††	11	15	19	27
30	300	0.45	††	12	16	21	29
30	350	0.49	††	15	19	25	33
36	150	0.38	††	--	9	14	21
36	200	0.42	††	8**	12	15	23
36	250	0.47	††	10	14	18	25
36	300	0.51	††	12	16	20	28
36	350	0.56	††	15	19	24	32

- 1 Ductile-iron pipe is adequate for the rated working pressure indicated for each nominal size plus a surge allowance of 100 psi. Calculations are based on a 2.0 safety factor times the sum of working pressure and 100 psi surge allowance. (See ANSI/AWWA C150/A21.50 for design formulas.) Ductile iron pipe for working pressures higher than 350 psi is available.
- 2 An allowance for a single H-20 truck with 1.5 impact factor is included for all depths of cover.
- ‡ Calculated maximum depth of cover exceeds 100 ft.
- * Minimum allowable depth of cover is 3 ft.
- ** For pipe 14 in. and larger, consideration should be given to the use of laying conditions other than type 1.

LAYING CONDITIONS



Type 1*
Flat bottom trench.+ Loose backfill.

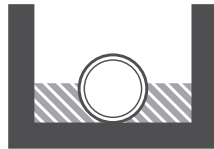

Type 2*
Flat bottom trench.+ Backfill lightly consolidated to centerline of pipe.

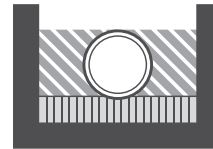

Type 3*
Pipe bedded in 4" min. loose soil.** Backfill lightly consolidated to top of pipe.

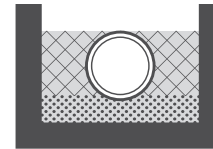

Type 4*
Pipe bedded in sand, gravel or crushed stone to depth of 1/8 pipe diameter, 4" min. Backfill compacted to top of pipe.(Approx. 80% Standard Proctor, AASHTO T-99.)

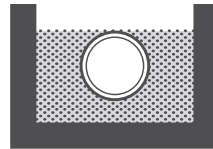

Type 5*
Pipe bedded in compacted granular material to centerline of pipe. Compacted granular or select** material to top of pipe.(Approx. 90% Standard Proctor, AASHTO T-99.)

NOTES Consideration of the pipe-zone embedment conditions included in this figure may be influenced by factors other than pipe strength. For additional information on pipe bedding and backfill, see ANSI/AWWA C600.

- † Flat bottom is defined as undisturbed earth.
- * For nominal pipe 14 in. and larger, consideration should be given to the use of laying conditions other than Type 1.
- ** Loose soil or select material is defined as native soil excavated from the trench, free of rocks, foreign materials and frozen earth.
- ‡ American Association of State Highway and Transportation Officials, 444 N. Capitol Street NW, Suite 225, Washington, DC 20001.

PIPE ASSEMBLY

FIG. 1 GASKET INSERTION

The inside of sockets and the outside of spigots should be cleaned up to the insertion depth. Gaskets should be wiped clean and inspected for damage. The gasket should then be placed into the socket groove, rounded end entering first. Seating the gasket is made easier by forming the gasket into a loop during insertion. The heel of the gasket should fit uniformly into the retainer seat. On pipes larger than 12", additional loops may help in placing the gasket in the seating.

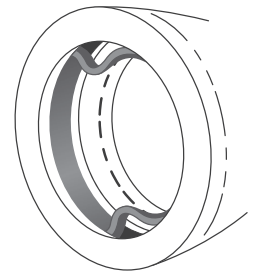

FIG. 2 LUBRICATION

Ensure that the spigot end is properly chamfered or rounded to avoid tearing of the gasket. Clean away all foreign matters from contact area of pipe. Apply a thin film of recommended lubricant to the mating surface of the gasket. Avoid spray-on lubricants as these may not provide enough lubrication. Avoid petroleum based lubricant as it may damage the gaskets. Once lubricated, do not let lubricated area touch the ground or other contaminant, compromised seal could result.

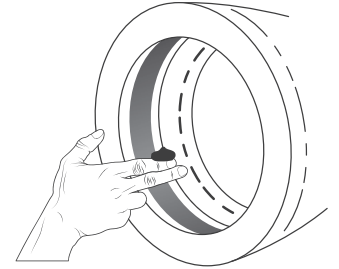

FIG. 3 PIPE AND FITTING AND ASSEMBLY

Spigot should be inserted in socket. If socket is pushed, the gasket may be displaced. Align and center the spigot in the socket and keep it in this position. Now gently push the spigot into the socket by suitable mechanical means, maintaining the alignment and level. A suitable gap should be left between the spigot end and the bottom of the socket to take care of any axial movement, deflection or temperature variation. To ensure this, two band marks are made near the spigot end. These bands act as a 'Go' and 'No-Go' gauge. After jointing, the end of the socket must end between these two bands. If moderate force does not result in a solid seal, remove the pipe and inspect for foreign matters, improper lubrication or misaligned gasket. Once you are certain of a solid seal, joint deflection can be applied within the permissible limits.

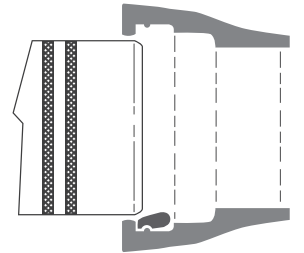
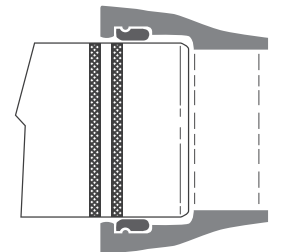

FIG. 4 INSPECTION OF JOINT

Verification of the gasket's position is easily accomplished with a feeler gauge. Insert the gauge into the joint until it touches the gasket. Check the gasket position all around the joint, making note of the depth required to contact the gasket. Any changes in depth indicate the gasket has slipped out of place. If this is the case, disassemble joint and clean all pipe contact areas and gasket. Once inspected for the fault, reassemble using the guidelines above.



PREPARING A FIELD-CUT PIPE

Pipe that has been cut on site can easily be made ready for use by giving the plain end a bevel. With a portable grinder, create a 16° angle around the outside edge of the cut end. The edge of bevel and plain end of the pipe should be rounded off with the grinder. Grinding should produce a bevel that continues back about 1" from the edge. This bevel will ease assembly and protect the gasket from damage by removing rough edges.

Special consideration should be given to cutting pipe 14" or larger. In this case, pipe should be gauged full length.* Pipe that is gauged full length will be marked as such and conforms to ANSI/AWWA C151 Standard for Ductile Iron Pipe requiring spigot end factory gauging.

To ensure tolerances, pipe for field cutting needs field gauging at the point of where the cut is to be made. Mechanical joint glands can be used for field gauging.

* **NOTE** A full length gauged pipe is a pipe whose outside diameter is within the spigot diameter specifications. Full gauged pipes should be specially ordered.

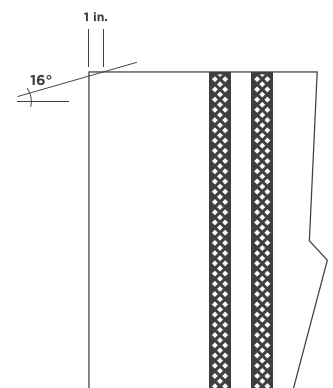

ALTERNATE METHODS FOR ASSEMBLY

Electrosteel USA recommends following the procedures outlined in the previous section before attempting the alternatives listed below.

ASSEMBLY USING A CROWBAR

For smaller sizes (for 3" to 6" dia.) a crowbar may be used for assembly. This method involves using a crowbar as a lever and pushing against the face of the bell. The pipe socket face must be protected with a piece of hard wood.

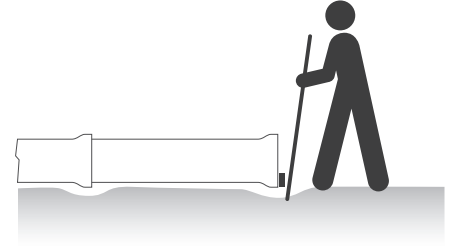

ASSEMBLY WITH A BACKHOE (for all DN)

Taking a few precautions, it is possible to use the hydraulic force of the arm of a mechanical digger to assemble pipes and straight fittings. In this case:

- Place a wooden batten between the pipe and digger bucket
- Exert a slow and steady force observing the rules for joint assembly
- A timber block should be placed between the bucket and the pipe to avoid damage of the socket.

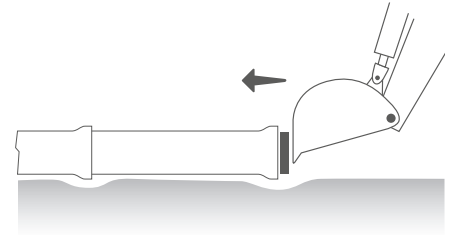

4" - 24" **PUSH BITE** RJ GASKET

PushBite RJ Gaskets are easy to install and conform to ANSI/AWWA C111/A21.11 requirements. A PushBite RJ Gasket's proven design and tough SBR-styrene butadiene rubber construction ensures a tight, fault-less assembly. PushBite RJ Gaskets made of alternative elastomers are available for special requirements. All PushBite RJ Gaskets are rated to 350 psi and offer an outstanding seal – suitable for water, wastewater, fire protection and other related applications. PushBite RJ Gaskets are available in diameters 4" to 24".



NOMINAL SIZE	DIAMETER MIN	DIAMETER MAX	MAX JOINT DEFLECTION**	ASSEMBLY MARK LOCATION*	APPROX RADIUS OF CURVE PRODUCED BY SUCCESSION OF JOINTS	DEFLECTION OF 18 FT LENGTHS
4	4.74	4.86	5°	2 - 3/4	205 FT	19
6	6.84	6.96	5°	2 - 15/16	205 FT	19
8	8.99	9.11	5°	3 - 1/4	205 FT	19
10	11.04	11.16	5°	3 - 5/16	205 FT	19
12	13.14	13.26	5°	3 - 5/16	205 FT	19
14	15.22	15.35	4°	4 - 9/16	257 FT	15
16	17.32	17.45	4°	4 - 9/16	257 FT	15
18	19.42	19.55	4°	4 - 9/16	257 FT	15
20	21.52	21.65	2.5°	5 - 1/16	412 FT	9.5
24	25.72	25.85	2.5°	5 - 1/2	412 FT	9.5

- Dimensions in inches unless otherwise noted.
- * For full deflection application, insert spigot no deeper than the first assembly stripe.
- ** The pipe to be installed must be kept in straight alignment with the previously installed pipe or fitting during assembly. Joint deflection may be made upon completion of the assembly.



ELECTROSTEEL COMPLIES TO THE FOLLOWING STANDARDS FOR DIP & FITTINGS

Thickness Design of Ductile Iron Pipe	ANSI/AWWA C150/A21.50
Ductile Iron Pipe for Water and Other Liquids	ANSI/AWWA C151/A21.51
Ductile-Iron Pipe for Gravity Flow Service	ANSI/ASTM A746
Ductile Iron Compact Fittings	
3" through 48"	ANSI/AWWA C153/A21.53
Flanged Fittings	ANSI/AWWA C110/A21.10 ANSI B16-1
Ductile Iron Pipe with Threaded Flanges	ANSI/AWWA C115/21.15
Coatings and Linings:	
Asphaltic	ANSI/AWWA C151/A21.51 ANSI/AWWA C110/A21.10 ANSI/AWWA C153/A21.53
Cement Lining	ANSI/AWWA C104/A21.4
Various Epoxy Linings and Coatings	MANUFACTURER'S STANDARD
Exterior Polyethylene Encasement	ANSI/AWWA C105/A21.5
Zinc Exterior Coating 200g/m	ISO: 8179
Joints - Pipe and Fittings	
Push-On and Mechanical Rubber-Gasket Joints	ANSI/AWWA C111/A21.11
Flanged	ANSI/AWWA C115/A21.15 ANSI B16.1
Grooved and Shouldered	ANSI/AWWA C606
Pipe Threads	ANSI/B2.1
Installation	ANSI/AWWA C600

For our full product details please visit
www.ElectrosteelUSA.com.



LOCATIONS:

1777 S. Argonaut Street
 Stockton, CA 95206
 421 Telfair Rd.
 Savannah, GA 31415

CONTACT:

912.387.0613 P
 912.385.0315 F
support@ElectrosteelUSA.com